

Electric Micro Dehumidifier

ROSAHL

Product Specification

Model : PD2



RYOSAI TECHNICA CO.,LTD.

1. Application

This specification document is applied to model PD2 of Electric Micro Dehumidifier "ROSAHL".

2. Outline

Drawing No. : RB-RPDX0005 (Refer to page 6)

3. Specifications

- 1) Applicable Volume : ~ 2,000cc
- 2) Element Terminal Voltage : 2.9 ~ 3.3V DC
- 3) Power Consumption : 80mW (at 20 deg C, 60%RH)
- 4) Weight : 0.9g
- 5) Operating Temperature : -10 ~ 50 deg C
- 6) Operating Humidity : 90%RH or less
- 7) Storage Temperature : -20 ~ 60 deg C
- 8) Storage Humidity : 90%RH or less
- 9) Connecting Type : Soldering (Wire diameter : AWG28~26)
- 10) RoHS Directive : Less than the legal limit of the ten substances

4. Ability and Characteristics

- 1) Dehumidifying Performance : 84mg/day (at 30 deg C, 60%RH) \*at the shipment
- 2) Rated Current : 50mA or less (at 30 deg C, 60%RH)
- 3) Inrush Current : 500mA (at 30 deg C, 60%RH) \*Reference value

5. Life

The dehumidifying performance will reduce during use. (How much it reduces depends on the operating environment and conditions.)

By the specifications of the applied product, the permissible level of the degradation of the Micro Dehumidifier changes, therefore the life is defined as half-life of performance.

Half-life of performance : About 4~6 years

\*Continuously operation at 18 deg C (Annual average temperature in Japan)

6. Indication \* Indicated the following items.

- 1) Model Name
- 2) Lot Number (Three columns of alphanumeric characters)

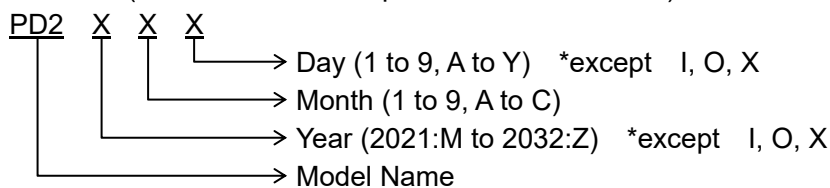

- 3) (+)polarity indicator (Concave Mark)

7. Inspection Items \*Must pass the inspection items bellow

- 1) Exterior (\*) : exterior inspection by visual (100% inspection)
- 2) Dehumidification Performance : (dehumidifying) operation check (100% inspection)  
(dehumidification) performance test (sampling inspection) 1/Lot
- 3) Marking : without problem (all)
- 4) Packing : without problem (all)

(\*) White deposits may be seen on dehumidifying surface.

These are materials of membrane attached during the manufacturing process.

They do not affect dehumidifying performance and its life.

8. Packaging Specifications

ROSAHL are packed as follows to avoid breakage failure while transport.

1) Packing case

Material : Polypropylene (t = 0.15mm)

Maximum capacity : 100 pcs. (10 × 10)

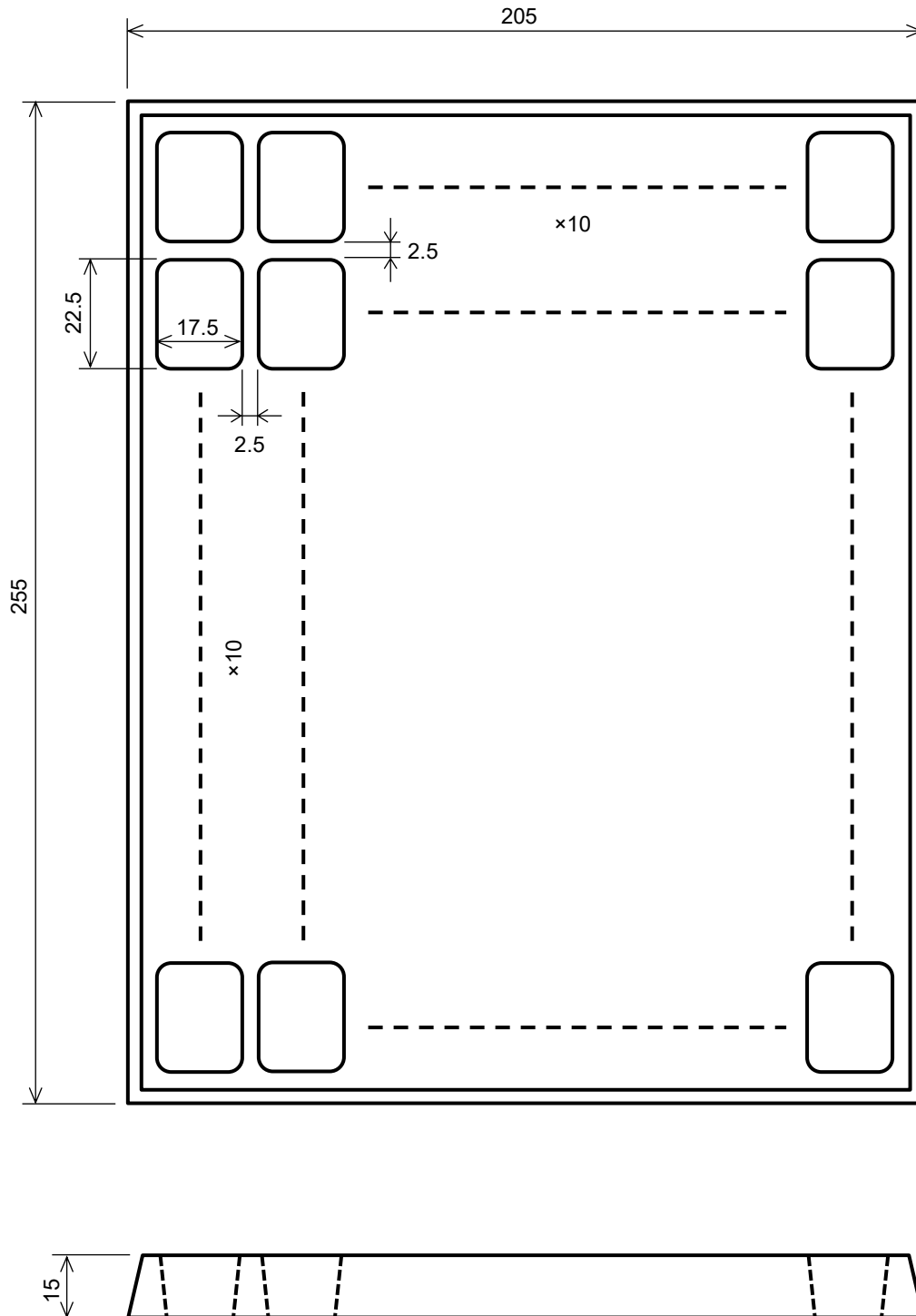

Fig.1 Packing case

2) Packing method

- (1) Put PD2 (Max. : 100 pcs.) in the packing case.
- (2) Pile up 6 cases (the top case is empty), cover top and bottom with the cardboard and fix 2 parts with rubber bands. (Refer to Fig.2)
- (3) Encase in a cardboard box and indicate model name and quantity. (Refer to Fig.3)

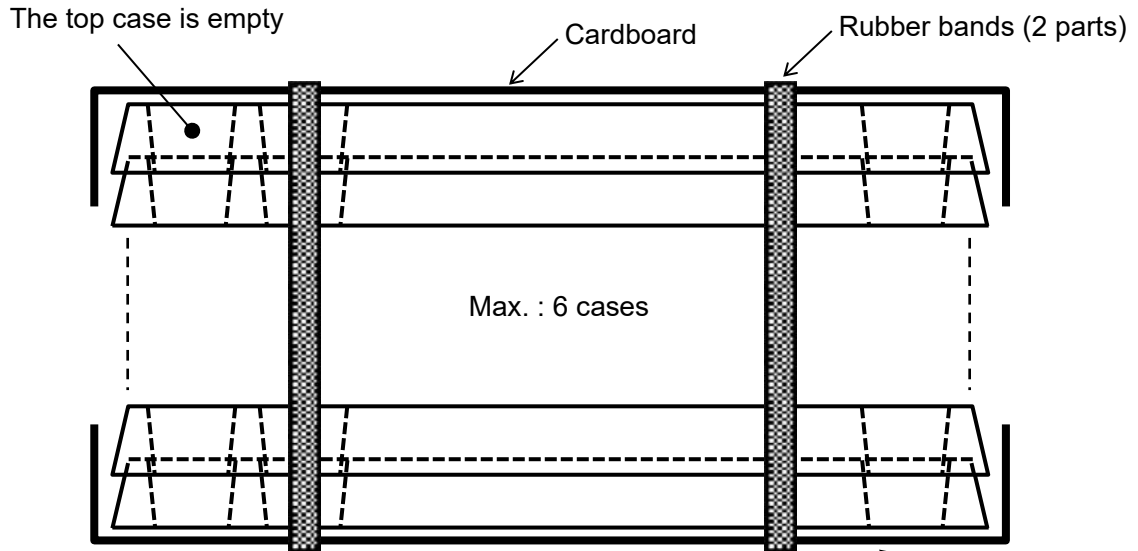

Fig.2

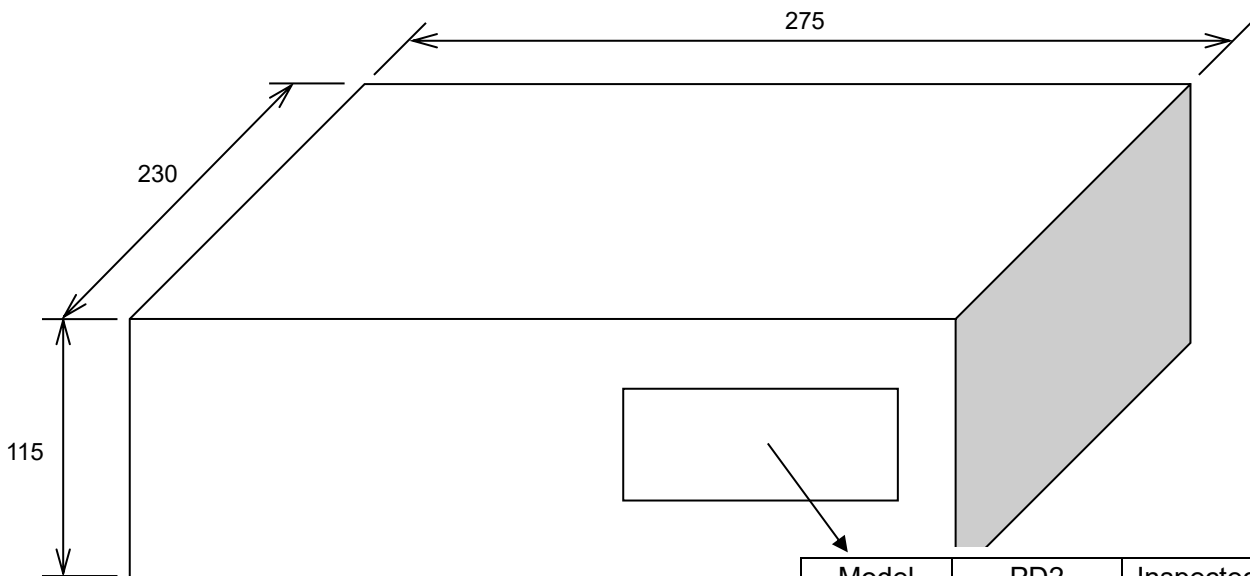

Fig.3

Model	PD2	Inspected
Quantity	XXX	
PRD.	mmm/yyyy	
No Lead		
RYOSAI TECHNICA CO., LTD.		

9. Precautions for Use of ROSAHL

- 1) Attach a protective cover as needed not to touch the dehumidifying / humidifying surface of a membrane with a hand and an object.
- 2) Confirm the dehumidifying / humidifying surface of a membrane not to get a wrong direction before installation. Attaching ROSAHL by mistake will adversely affect several things in the container.
- 3) Keep strictly the following about power supply to ROSAHL
  - (1) Do not reverse the polarity. Confirm a polarity indication of ROSAHL.  
Dehumidification changes to humidification when you get a wrong polarity, which may result in an adverse effect on several things in the container. Furthermore, it causes a chemical reaction in a porous electrode of cathode side and it causes the trouble of ROSAHL.
  - (2) ROSAHL usually has a big rush current when the power is turned on.  
Therefore, we recommend the following power supply.
  - (3) Use a dedicated power supply for each membrane. When multiple membrane are connected in series or parallel, the trouble of one membrane may cause all other membranes to be disabled.
  - (4) The water vapor go through a membrane of ROSAHL. If you switch off a power supply, outside water vapor is returned into a container and the humidity is restored.

Table 1. Recommended Power Supply Specifications

Rated output voltage	3V DC
Rated output current	500mA
Overcurrent protection function * Note	Required
Overvoltage protection function	Required
Output voltage variation	0.1V or less
Ripple noise	0.2V or less
Others	In accordance with the specifications of commercially available power supply

Note : Use a constant or fold-back current limiting regarding overcurrent protection function. You cannot use the power supply with the Hiccup mode current limiting type, because the voltage more than 2V is necessary for ROSAHL when an overcurrent protection function worked. Also ROSAHL may not work correctly depending on a characteristic of fold-back current limiting.

- 4) A container must be an airtightness container. If a container has low airtightness and moisture-permeable material, the results may not be what you expected.
- 5) Attach ROSAHL in the center of the side surface of a container with a gasket.  
(Do not attach it on a top or bottom surface.)  
If you use a silicon gasket, you need to vulcanize a gasket (200 deg C / 6 hours).  
If you do not vulcanize it, it will quickly degrade the performance of ROSAHL.  
Note : The silicon gasket assembled in ROSAHL is vulcanized. (conditions : 200 deg C / 6 hours)
- 6) If you use ROSAHL with a gasket that contains an antioxidant, crystal materials may be generated on the surface of a membrane. When you choose a gasket, evaluate it enough.
- 7) Do not use silicon-based sealing materials to improve airtightness of a container.  
(Silicon-based sealing materials generate oxime gas and siloxane gas.  
As a result, the performance of ROSAHL reduce in a short term.)  
Additionally, when using any other sealing materials, ROSAHL must be attached after sealing materials are completely cured. Volatile substances generated during curing affect the performance of ROSAHL.  
[Recommended products] : modified silicon caulk (Konishi Co., Ltd.)
- 8) Do not expose a moisture discharging side of a membrane to water. When using outdoors, be sure to attach a cover or vent filter to protect a membrane from water or insects.
- 9) Attach a moisture-permeable sheet to a membrane to protect ROSAHL from much dust or oil mists.  
[Recommended products] : Vent Filter TEMISH S-NTF2131A-S06 (Nitto Denko Corporation)
- 10) Keep the moisture discharging side of a membrane well ventilated.
- 11) Do not use ROSAHL with vapor phase corrosion inhibitor or insect repellent.  
Do not use ROSAHL in a place having high density of organic gas.
- 12) Do not do remodeling. An element may break down.

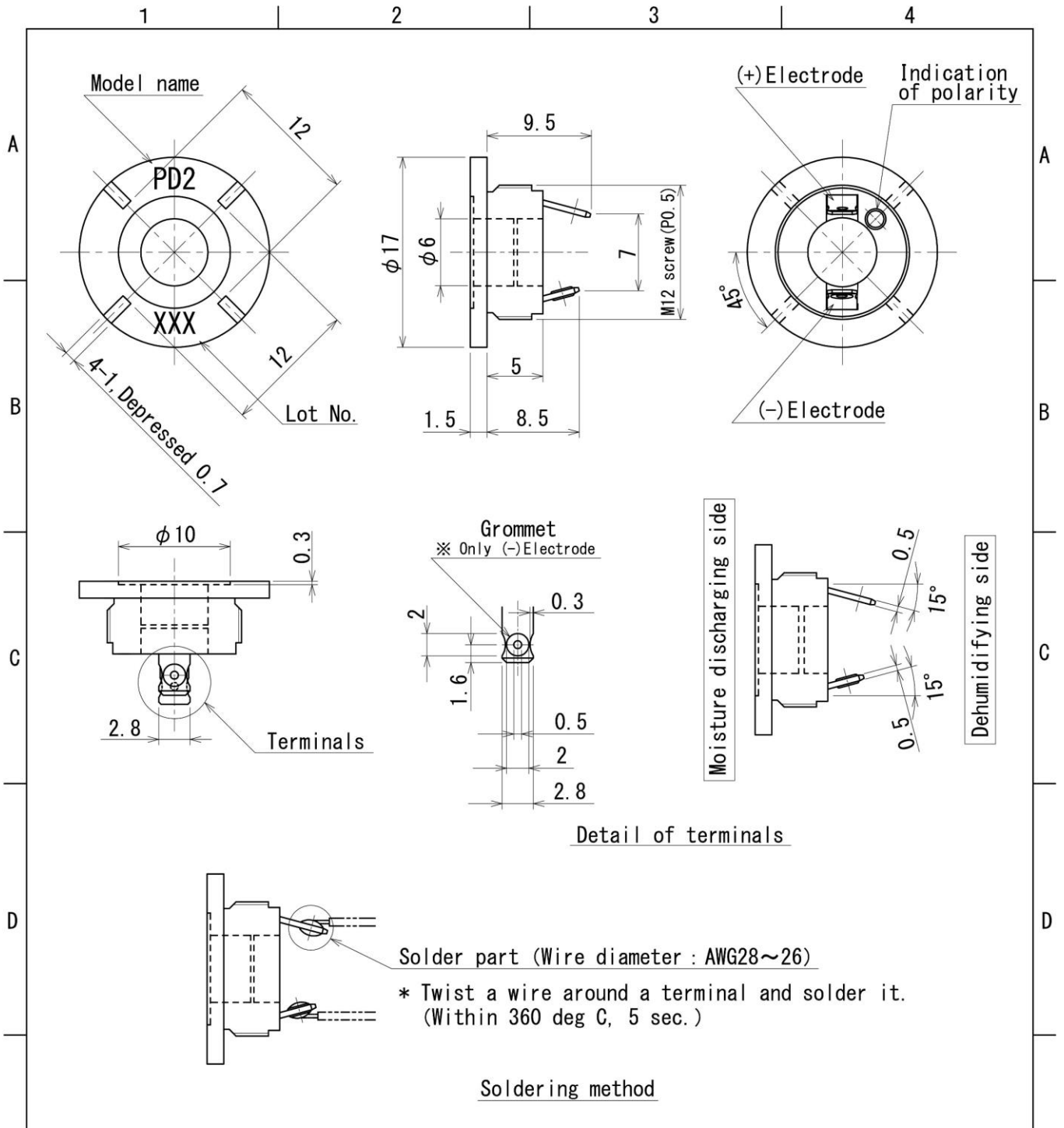

E	改定 CHANGE	
---	-----------	--

		RYOSAI TECHNICA CO., LTD.		Paper size : A4	
出図先			DRAWN 作成 Yabe	TITLE PD2	
WO	1	DIM. IN (mm)	CHECKED 照査 Kobayashi	Outline Drawing	
		SCALE 尺度 2 : 1 NTS	DESIGNED 設計 Kobayashi		
		DATE 作成日付 2021-06-08	APPROVED 検認 Hohmoto		
				DWG. NO. RB-RPDX0005	

1 2 3 4